



Bookcase Plan Combo Pack



Build Better Bookcases

We show you how to make a great bookcase in any style, with one basic box design and one sheet of plywood.

Everyone needs a bookcase, and if you're a beginning woodworker, it's a great project to develop skills without breaking the bank. Our staff got together to design the ideal bookcase. We wanted it to fit in the average home, look good and be made to last. We also wanted to show that the same basic construction could be dressed up in different ways to suit anyone's sense of style. Our goal was to produce a plan that would make good use of materials, and be relatively quick and easy to put together and finish. We held meetings, passed memos, e-mails and sketches around the office and, in the end, made the new guy (me) do all the work.

Basic Bookcase Construction

The basic cabinet is built from one 4' by 8' sheet of $\frac{3}{4}$ "-thick hardwood plywood plus a few board feet of solid wood. This keeps the cost reasonable, but introduces some constraints on the size of the finished bookcase. Our final design is 5' high and a little less than $2\frac{1}{2}$ '-wide. It's not quite as deep as many bookcases, but it is a useful size for all but the largest books. It does its job without taking over

the room, will hold a lot of books and the shelves won't sag. You can make the basic design any size you want, but if you make it larger you won't be able to get all of the parts from one sheet of plywood. If you make it wider, keep the shelves less than 36". If the shelves are longer than that, they will likely sag when loaded with books.

Using $\frac{3}{4}$ " plywood for the back as well as the other cabinet parts produces a box that is very strong. The edges of the plywood are all covered with solid wood. In three of the four designs this is a face frame applied to the front of the box. The other design uses $\frac{1}{4}$ "-thick hardwood as an edge band.

I used biscuit joints to hold the case together and pocket screws to join the face frames. The assembled face frame is glued to the front of the cabinet. There is enough surface area for a good joint, without nail holes showing in the completed cabinet.

Using plywood solves many problems you would have if you made the bookcase from solid wood; the grain and color of all the parts will be similar, you won't have to glue any parts together for width and seasonal wood movement won't be an issue.

by Robert W. Lang

Comments or questions? Contact Bob at 513-531-2690 ext. 1327 or robert.lang@fwpubs.com. Visit his web site at craftsmanplans.com.





SHAKER: Made from cherry plywood with a solid cherry face frame. The profiles for the mouldings were taken from typical details used in original Shaker pieces.

CONTEMPORARY: Made without a face frame from maple plywood with 1/4"-thick solid maple glued and nailed to the raw edges of the plywood.

ARTS & CRAFTS: Quartersawn white oak plywood and solid wood were used to construct the Arts & Crafts bookcase. The beveled mouldings were typical on built-in bookcases and other cabinets of the early 20th century.

FORMAL: The most complex bookcase is made from African mahogany plywood, with genuine mahogany face frame and mouldings. Additional mouldings are applied to the side to form panels.

Photo by Al Parrish

The Trouble with Plywood

Plywood however, does introduce some problems that you need to be aware of. The veneer face is very thin. You need to handle it carefully to avoid scratching it, and when you sand you need to be careful that you don't sand through the veneer. Despite what some people might tell you, the factory edges are not straight, and you should never assume that the corners of the sheet are square.

The other problem with plywood is its thickness. It will be between $\frac{1}{32}$ " and $\frac{1}{16}$ " less than $\frac{3}{4}$ ", and the thickness can vary throughout the sheet. If you cut the horizontal parts to the dimensions in the cutting list, your cabinet will finish slightly smaller in width. If you then cut the top and

make the face frame to the listed size, they won't quite fit. The first thing you need to do is determine the actual thickness. Then develop a strategy for working around this discrepancy.

I began by crosscutting the plywood at 60", as shown in the cutting diagram. This large piece will yield the two long sides of the bookcase and the back. The smaller piece will provide the top and bottom of the cabinet, as well as the fixed and adjustable shelves. There is a little extra room to allow for squaring the ends of the finished parts and cutting clean long edges. You can make this crosscut on the table saw, but it's easier to cut the full sheet with a circular saw and a straightedge. You could also make this first cut

with a jigsaw, and then clean up the edge with a router. If you go this route, clamp a straightedge to the sheet, make sure it's square and run a flush trimming bit against it to clean up the cut.

Make the first rip cut on the table saw $\frac{1}{4}$ " wider than the finished part. Then move the fence in to trim the opposite edge. Keep the best side up, and the freshly cut edges against the fence so that you have two clean edges on each part. After ripping, I crosscut the parts on a sliding compound miter saw, using a stop to make sure that pairs of parts were the exact same length, which is important.

The plywood I was using was $\frac{1}{32}$ " thinner than $\frac{3}{4}$ ", so I made the parts that go between the sides $\frac{1}{16}$ " longer than the listed length.

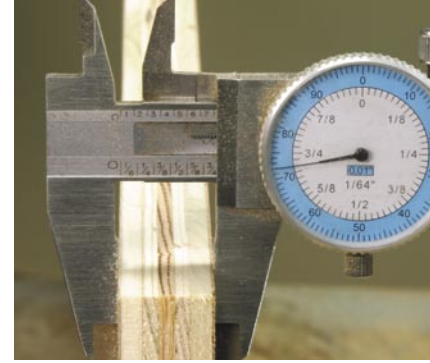

One of the most important facts about plywood is that it is almost always thinner than the stated dimension. This (one of four types) $\frac{3}{4}$ " plywood was $\frac{1}{32}$ " undersized.

This allows the cabinet to finish at the correct width.

Develop a Strategy

Look at the exploded drawing at right to understand how the parts of the basic carcass go together. The back sits in a $\frac{3}{4}$ "-wide by $\frac{1}{2}$ "-deep rabbet cut in the back edges of the sides, the bottom and the top. In the three versions with face



The rabbet at the back edge of the cabinet sides, bottom and top is made with a stack dado set on the table saw. The featherboard holds the plywood down flat to the surface of the saw.



The story stick, made from a scrap of plywood shows all of the cabinet parts at full size. Make one and put away your tape measure. Use it to lay out all of the parts quickly and accurately.

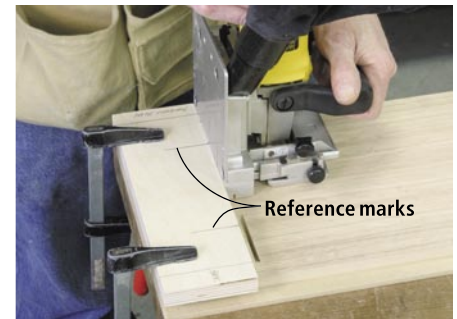

A second story stick acts as a jig to locate the biscuit slots in the cabinet sides. Reference marks for the slots line up with the centerline on the bottom of the machine.

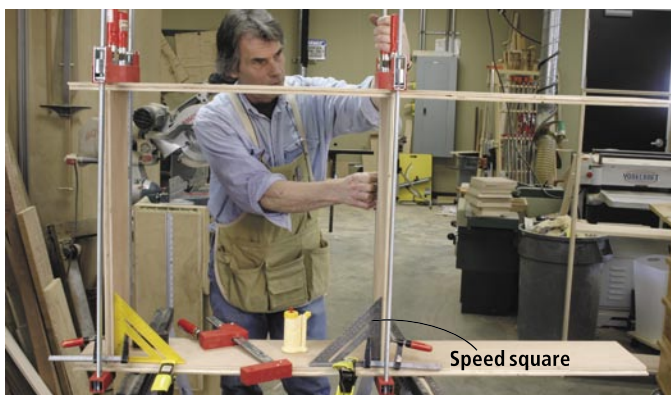

With the cabinet on its side, I can easily reach both the front and back edges to keep them flush. Speed squares clamped to the side and shelves keep the cabinet square during this glue-up.



I let the glue dry overnight before attaching the cabinet top. Because the top is placed above the cabinet sides I had to use clamps in pairs to hold the top down as shown here.

frames, the bottom and fixed shelf go between the cabinet sides, and the top sits on the upper edge of the sides. In the contemporary bookcase, one difference is that the top goes between the sides.

The fixed middle shelf is $\frac{3}{4}$ " narrower than the cabinet bottom so its back edge is even with the rabbet in the other parts. The top is $\frac{3}{4}$ " wider than the bottom, as the front edge covers the top of the face frame.

Cut the parts from the sheet of plywood in stages. I cut only the two sides, the bottom and the fixed shelf to final size before assembling the box. I then cut the top to the right width, and cut its rabbet in the back with the other parts, but I left it long until after the basic box was assembled.

If something went wrong with one of these parts, I could make them into adjustable shelves, and replace them with the parts from the remaining plywood. This is less efficient than cutting all the parts at once, but it's insurance against mistakes.

I cut the rabbet with a stack dado set in the table saw, using a featherboard to hold the stock down (as shown at left). Plywood is often bowed, and if it raises up while it is going across the dado stack, the rabbet won't be a consistent depth. Making the rabbet $\frac{1}{2}$ " deep gives room to attach the back with #6 x $1\frac{5}{8}$ " screws.

stick, $\frac{3}{4}$ " wide by $10\frac{3}{8}$ ". This was used to locate the slots for the biscuits in the cabinet sides, and in the edges of the bottom piece and the fixed shelf. I clamped this to the bottom edge of the cabinet sides, placed the bottom of the biscuit joiner against the marks and cut the slots.

To set the height of the cutter for the slots in the ends of the

shelves, I placed a shelf flat on the bench, set the biscuit joiner next to it, and lowered the fence until it was flush with the top surface of the shelf. This indexes the machine so the slots cut using the guide block line up with the slots cut using the machine's fence.

With all the joints ready, it's tempting to go ahead and glue the cabinet together. It is faster, and you get a better finish if at this point you finish sand all of the inside surfaces, then assemble.

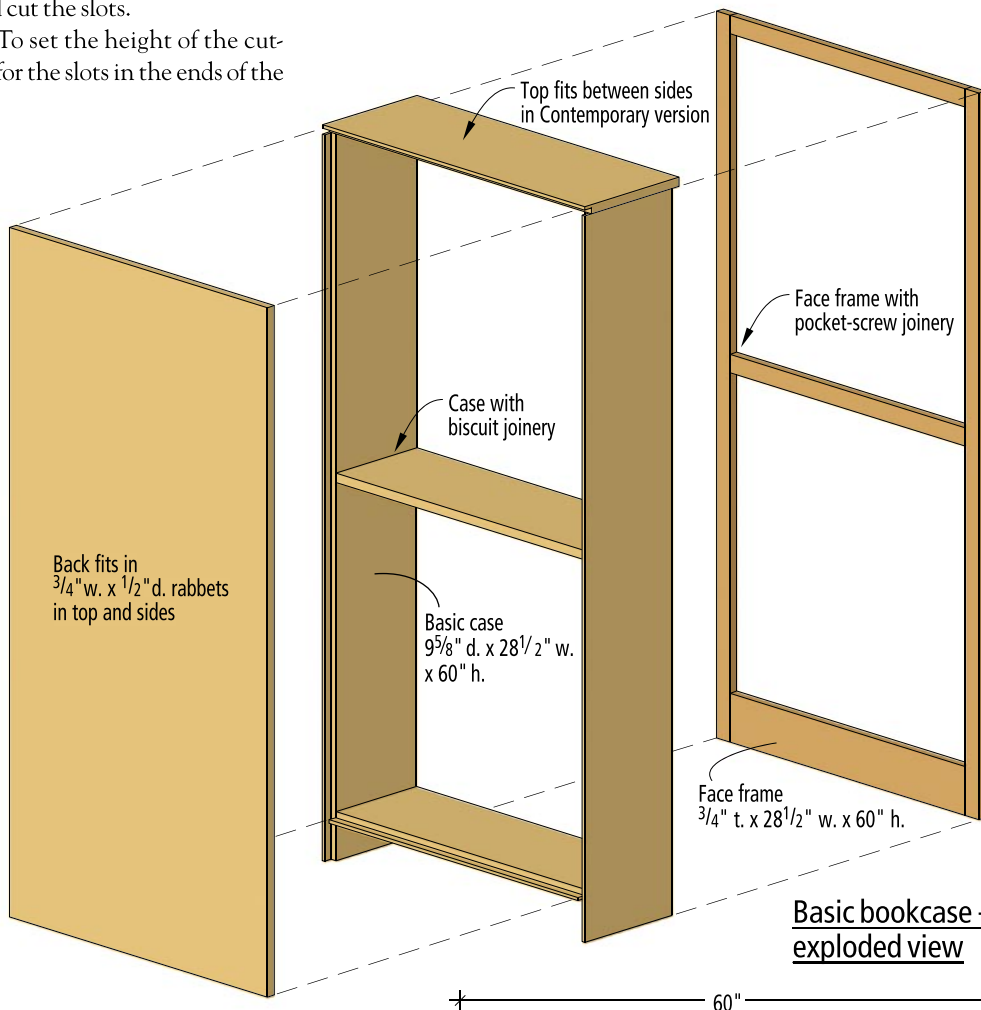

Basic bookcase - exploded view

Making Layout Simple

With the carcass parts cut and rabbeted, I took a 60"-long piece of scrap plywood and made a story stick, showing at full scale the positions of the plywood parts, as well as the parts for the face frame. The most likely place to make a mistake is in measuring, and the story stick transfers the locations to the finished parts without measuring (as shown at left).

I also made a second story

Cutting diagram

Adj. shelf	8 $\frac{1}{8}$ " x 26 $\frac{7}{8}$ " - A&C, S	Back - 28" x 56 $\frac{1}{4}$ "	A&C - Arts & Crafts S - Shaker C - Contemporary F - Formal
	8 $\frac{5}{8}$ " x 26 $\frac{7}{8}$ " - C		
	8 $\frac{3}{4}$ " x 26 $\frac{7}{8}$ " - F		
Adj. shelf	8 $\frac{1}{8}$ " x 26 $\frac{7}{8}$ " - A&C, S	Side - 9 $\frac{5}{8}$ " x 59 $\frac{1}{4}$ " - A&C, S, F	9 $\frac{5}{8}$ " x 59 $\frac{3}{4}$ " - C
	8 $\frac{5}{8}$ " x 26 $\frac{7}{8}$ " - C		
	8 $\frac{3}{4}$ " x 26 $\frac{7}{8}$ " - F		
	Fixed shelf - 8 $\frac{7}{8}$ " x 27"		
	Bottom - 9 $\frac{5}{8}$ " x 27"		
Top	10 $\frac{3}{8}$ " x 28 $\frac{1}{2}$ " - A&C, S	Side - 9 $\frac{5}{8}$ " x 59 $\frac{1}{4}$ " - A&C, S, F	9 $\frac{5}{8}$ " x 59 $\frac{3}{4}$ " - C
	9 $\frac{5}{8}$ " x 27" - C		
	10 $\frac{3}{8}$ " x 30" - F		

Arts & Crafts Style



The Arts & Crafts bookcase and the Shaker bookcase are constructed the same way. I assembled the cabinet with one side across two sawhorses. This let me position clamps across both sides of each joint. I clamped a speed square on each of two opposite corners to keep the box square while the glue dried.

Before attaching the top, I still needed to cut it to its exact length. Instead of relying on the cutting list, I checked the outside dimension of the assembled box to be certain to get a good fit without the undersized plywood throwing me off. I held the top in place against the ends of the sides and made a couple of marks for the bis-

cuts. To clamp the top in position, I had to hook two clamps together as shown on page 34.

I put together the basic box with the bottom and fixed shelf between the sides, and the top of the cabinet above the sides. Before working on the face frame, I made sure that all the edges on the cabinet were flush by sanding them with a sanding block (shown below). It's simply a piece of plywood 3" wide with a piece of a sanding belt glued to it. By holding it flat on two adjacent surfaces, any variations can be quickly removed so that the face frame will sit flat.

The face frame is assembled and glued to the front edge of the

plywood box. The outside edges of the face frame are flush with the outside faces of the plywood when the cabinet is complete, but you want to make the face frame so that it extends slightly beyond the veneer. If you try to make it dead flush you are likely to end up with the veneer proud of the solid wood frame at some point. If this happens it's almost impossible to correct without sanding through the thin veneer.

Put Your Tape Away

Instead of measuring the parts for the face frame, I put the assembled cabinet on its back, and clamped the stiles to the front edges of the plywood, letting the long edges



Before attaching the face frame, sand the front edges flush with a flat sanding block. I used a cloth-backed sanding belt glued to plywood.



With the stiles clamped to the assembled box, I mark both the length and the exact location of the rails directly. This eliminates errors due to measuring or using undersized plywood.



The face frame is put together with pocket screws before being glued in place on the assembled cabinet box. Two clamps hold the stile on edge so that I can see and reach both sides of the joint.



It might take every clamp you own, plus a few borrowed from a neighbor, to attach the face frame. It's worth the effort to get it lined up perfectly without leaving nail holes to be filled.



It's safer to trim the solid wood parts down to the plywood parts. The block plane works quickly against an edge or against the veneer.



A card scraper brings the solid wood even with the plywood without raising a cloud of dust, or risking the damage that a belt sander or random-orbit sander could cause.

ARTS & CRAFTS-STYLE BOOKCASE

hang over the plywood about $\frac{1}{32}$ ". Then I marked the length and the location of the rails directly from the plywood parts. Once the rails are the correct length, I used a pocket-hole jig to drill holes in the ends of each rail.

After assembling the face frame, it is glued down to the plywood. It takes a lot of clamps to get a nice tight glue line. The face frame can be nailed down, but that means filling all the holes.

Where Solid Meets Ply

After letting the glue on the face-frame-to-cabinet joint dry overnight, it was time to clean up where the plywood and solid wood meet. Because the solid wood was proud of the veneer, I could use a block plane and scraper to bring the surfaces flush.

In the past I've used a random-orbit sander or belt sander for this task, but I have found that using the plane and card scraper is faster, does a better job and there is a lot less risk of going through the plywood's thin face veneer.

The trim around the front and sides of the plywood cabinet top is mitered at the corners, and glued to the edges. If these trim pieces are bowed, I use a few biscuits to help keep the solid wood flush with the plywood.

I glued the solid-wood edges to the two adjustable shelves, and then bored the holes for the adjustable shelf pins using a jig I made, shown on page 38. You may need to trim the shelves to fit behind the face frame. I then sanded everything inside and out to #240 grit to prepare it for finishing.

The crown and base mouldings for the Arts & Crafts cabinet are made with 30° bevel cuts. I made the cuts on the table saw and then removed the saw marks with my block plane.

NO.	ITEM	DIMENSIONS (INCHES)			MATERIAL	COMMENTS
		T	W	L		
2	Sides	$\frac{3}{4}$ "	$9\frac{5}{8}$ "	$59\frac{1}{4}$ "	Plywood	QSWO*
1	Bottom	$\frac{3}{4}$ "	$9\frac{5}{8}$ "	27"	Plywood	QSWO
1	Fixed shelf	$\frac{3}{4}$ "	$8\frac{7}{8}$ "	27"	Plywood	QSWO
1	Top	$\frac{3}{4}$ "	$10\frac{3}{8}$ "	$28\frac{1}{2}$ "	Plywood	QSWO
1	Back	$\frac{3}{4}$ "	28"	$56\frac{1}{4}$ "	Plywood	QSWO
2	Adj. shelves	$\frac{3}{4}$ "	$8\frac{1}{8}$ "	$26\frac{7}{8}$ "	Plywood	QSWO
2	Stiles	$\frac{3}{4}$ "	$1\frac{1}{2}$ "	$59\frac{1}{4}$ "	Solid	QSWO
2	Rails	$\frac{3}{4}$ "	$1\frac{1}{2}$ "	$25\frac{1}{2}$ "	Solid	QSWO
1	Bottom rail	$\frac{3}{4}$ "	4"	$25\frac{1}{2}$ "	Solid	QSWO
2	Shelf edges	$\frac{3}{4}$ "	$1\frac{1}{2}$ "	$26\frac{7}{8}$ "	Solid	QSWO
1	Top trim	$\frac{3}{4}$ "	1"	60"	Solid	QSWO
1	Top trim	$\frac{1}{2}$ "	$\frac{3}{4}$ "	60"	Solid	QSWO
1	Base trim	$\frac{3}{4}$ "	$3\frac{3}{4}$ "	60"	Solid	QSWO

*Quartersawn white oak

The Arts & Crafts finish consists of General Finishes' Java gel stain, followed by amber shellac. After a coat of wax, I put the back in place, attaching it with #6 x $1\frac{5}{8}$ " screws.

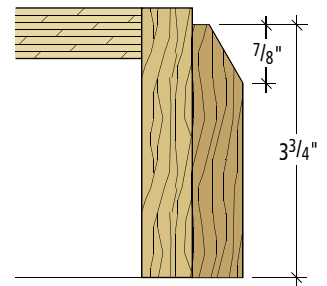
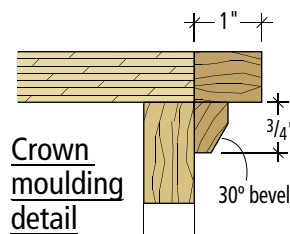

Base moulding detail

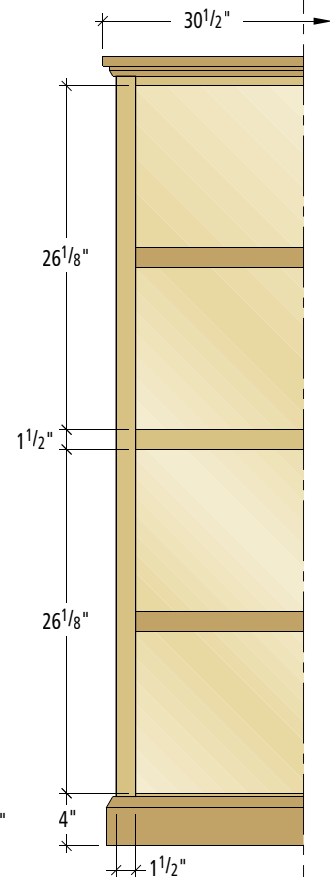
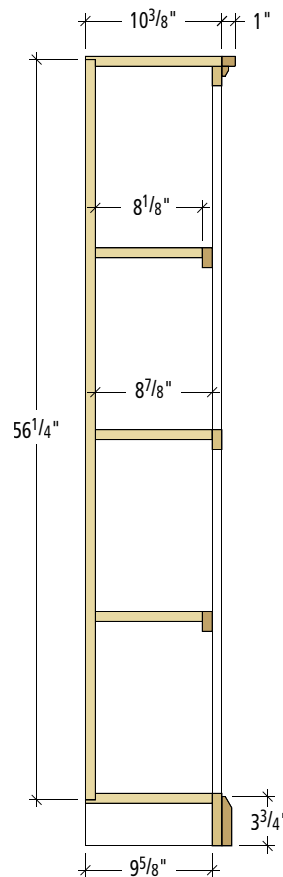
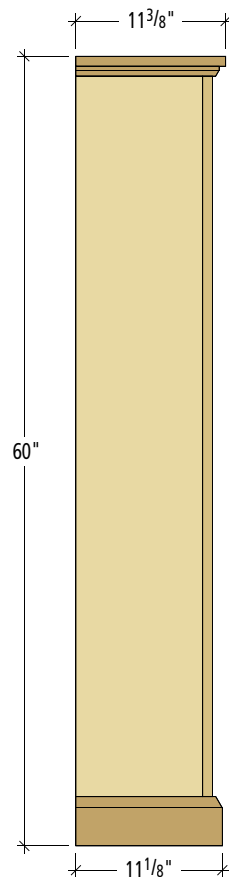
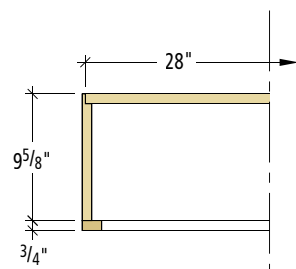

Shaker Style



The Shaker bookcase is assembled and trimmed in the same way as the Arts & Crafts case. The only difference between the two is the profile of the mouldings, the species of wood and the finish.

All of these mouldings were made on the router table. The bullnose trim around the top of the cabinet can be made with two passes over a $\frac{3}{8}$ "-radius quarter-round bit, or one pass over a bullnose cutter. Either way, leave a slight flat spot at the center of the radius. If you machine off the entire curve, the wood will move

toward the router bit at the end of the cut and leave a snipe in the last few inches of the moulding.

The cove moulding starts as a $\frac{3}{4}$ " x $\frac{3}{4}$ " piece of square stock. The $\frac{5}{8}$ " radius was milled on the router table. The base moulding is a $\frac{1}{2}$ "-radius bead with the cutter set to be flush with the face of the moulding at one end, leaving a $\frac{1}{4}$ " x $\frac{1}{8}$ " step at the top edge. Use a pair of featherboards to hold the stock down to the router table and tight to the fence while making the mouldings. Make one pass to remove most of the waste, and then reset the router to make a final, light finishing pass.

Apply the Trim

Putting the trim around the edges of the top is the most exacting part of this project. I added an auxiliary fence and table to my miter saw, as shown on page 40 and I then made a 45° cut in each direction so that I would have a reference to exactly where the cut would be made. I marked the cuts directly from the assembled cabinet and lined up the marks to the kerf in the auxiliary fence and table.

After I made the mouldings on the router table, I cut the pieces of trim a few inches longer than needed. I then made a 45° cut on

one end of each of the three pieces. This let me check the angle at the corners. I held one end of the front piece against one of the short legs, and then marked the other end by running my pencil across the back of it, where it met the side of the cabinet. I usually make the cut just a little long, check the angle with the mating piece and then make the final cut.

The trim is glued to the cabinet, no nails are necessary. I trimmed the top first, and then scraped the top edge flush with the veneer.

The Shaker cabinet is finished with Watco Danish oil. I wanted to add a bit of color to the wood so I mixed half medium walnut and half natural together, and applied two coats of oil followed by one coat of paste wax.



I used a shop-made jig to drill the holes for the pegs for the adjustable shelves. $\frac{1}{4}$ "-20 T-nuts act as bushings to guide a brad-point drill bit. After drilling the holes for the T-nuts on 1" centers top-to-bottom, I used a twist drill bit to bore out the soft threads in the T-nuts, leaving a $\frac{1}{4}$ " diameter.

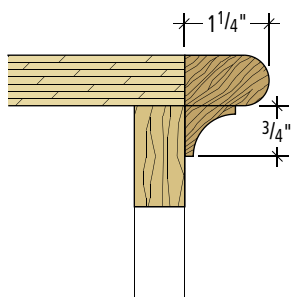

Crown moulding detail

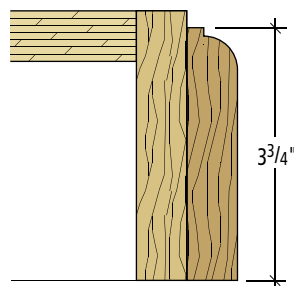

Base moulding detail

SHAKER-STYLE BOOKCASE

NO.	ITEM	DIMENSIONS (INCHES)			MATERIAL	COMMENTS
		T	W	L		
2	Sides	$\frac{3}{4}$ "	$9\frac{5}{8}$ "	$59\frac{1}{4}$ "	Plywood	Cherry
1	Bottom	$\frac{3}{4}$ "	$9\frac{5}{8}$ "	27"	Plywood	Cherry
1	Fixed shelf	$\frac{3}{4}$ "	$8\frac{7}{8}$ "	27"	Plywood	Cherry
1	Top	$\frac{3}{4}$ "	$10\frac{3}{8}$ "	$28\frac{1}{2}$ "	Plywood	Cherry
1	Back	$\frac{3}{4}$ "	28"	$56\frac{1}{4}$ "	Plywood	Cherry
2	Adj. shelves	$\frac{3}{4}$ "	$8\frac{1}{8}$ "	$26\frac{7}{8}$ "	Plywood	Cherry
2	Stiles	$\frac{3}{4}$ "	$1\frac{1}{2}$ "	$59\frac{1}{4}$ "	Solid	Cherry
2	Rails	$\frac{3}{4}$ "	$1\frac{1}{2}$ "	$25\frac{1}{2}$ "	Solid	Cherry
1	Bottom rail	$\frac{3}{4}$ "	4"	$25\frac{1}{2}$ "	Solid	Cherry
2	Shelf edges	$\frac{3}{4}$ "	$1\frac{1}{2}$ "	$26\frac{7}{8}$ "	Solid	Cherry
1	Top trim	$\frac{3}{4}$ "	$1\frac{1}{4}$ "	60"	Solid	Cherry
1	Top trim	$\frac{3}{4}$ "	$\frac{3}{4}$ "	60"	Solid	Cherry
1	Base trim	$\frac{3}{4}$ "	$3\frac{3}{4}$ "	60"	Solid	Cherry

Contemporary Style



This bookcase is made without a face frame. It is lighter and simpler in appearance, and takes less time to build and finish. Instead of a face frame, the visible front edges of the plywood are covered with $\frac{1}{4}$ "-thick strips of solid wood.

The plywood sides of this cabinet are cut to a finished length of $59\frac{3}{4}$ " and a piece of edge trim is put on the ends before the front trim is applied. The top piece in this version is the same size as the bottom, and fits in between the sides. Because of this, the basic cabinet carcass should be assembled in one step.

Trim Now, Assemble Later

The solid edges are applied and trimmed before the cabinet box is put together. I ripped the strips to $\frac{3}{8}$ " and then took them down to $\frac{1}{4}$ " thick by making two passes through the planer. The solid maple I used had been planed to $\frac{1}{32}$ " over $\frac{3}{4}$ ", so the strips were about $\frac{1}{16}$ " wider than the plywood was thick. This extra width makes it easy to attach the strips without worrying about lining up the edge of the solid wood perfectly.

I trimmed the solid wood down to the level of the plywood with a block plane followed by a card scraper. You could use a router with a flush-trimming bit, but it's awkward to try to balance the base of the router on the edge of the piece. If the router tilts at all, the

bit will dig in and ruin the edge. The router bit will also likely tear out a piece of the solid wood if the grain direction isn't consistent.

Assemble the box after applying the edges. Below the bottom shelf is a $3\frac{1}{4}$ "-high, 27"-wide (grain runs vertically) piece of plywood to support the bottom shelf. The face of this kick board piece is set in $\frac{1}{4}$ " from the edge of the cabinet sides. I finished the bookcase with Minwax Polycrylic Semigloss clear finish.

I clamped each part vertically on the bench to attach the edges with glue and 23-gauge pins. The edges are wider than the plywood is thick.



Before assembling the cabinet, trim the solid wood edges flush to the plywood using a block plane followed by a card scraper. I sanded all the parts before assembly.

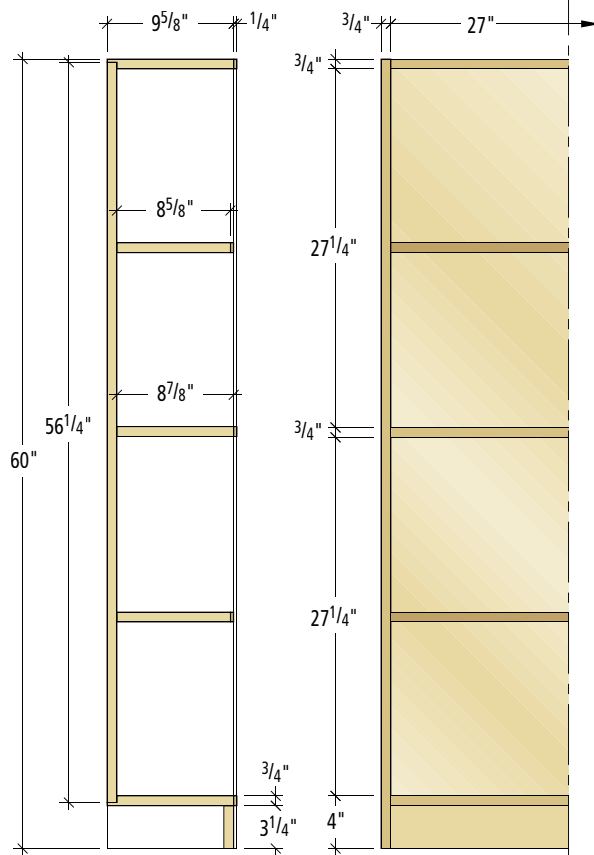
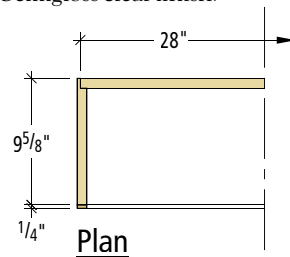

Section

Elevation

CONTEMPORARY-STYLE BOOKCASE

NO.	ITEM	DIMENSIONS (INCHES)			MATERIAL	COMMENTS
		T	W	L		
□ 2	Sides	$\frac{3}{4}$ "	$9\frac{5}{8}$ "	$59\frac{3}{4}$ "	Plywood	Maple
□ 2	Top & bottom	$\frac{3}{4}$ "	$9\frac{5}{8}$ "	27"	Plywood	Maple
□ 1	Fixed shelf	$\frac{3}{4}$ "	$8\frac{7}{8}$ "	27"	Plywood	Maple
□ 2	Adj. shelves	$\frac{3}{4}$ "	$8\frac{1}{8}$ "	$26\frac{7}{8}$ "	Plywood	Maple
□ 1	Back	$\frac{3}{4}$ "	28"	$56\frac{1}{4}$ "	Plywood	Maple
□ 1	Kick board	$\frac{3}{4}$ "	27"	$3\frac{1}{4}$ "	Plywood	Maple
□ 1	Edge trim	$\frac{1}{4}$ "	$25\frac{3}{32}$ "	30LF*	Solid	Maple

*Linear feet

Formal Style



The plywood case of the formal cabinet is assembled the same way as the other two face-frame cabinets, but the top and the face frame are both larger to accommodate the paneled trim on the outside of the bookcase. The shelves are also deeper. Instead of tucking behind the face frame, they sit $\frac{1}{8}$ " back from the front of the face frame.

The edge of the face frame is flush with the inside edge of the cabinet side instead of the outside. This allows for the addition of pieces of solid wood on the outside of the cabinet to look like paneling. The top also overhangs the

side of the cabinet $\frac{3}{4}$ " so that it is above the paneling. The joint between the two is covered by the crown moulding.

Make the face-frame stiles $1\frac{9}{16}$ " wide so that the edges of the face frame are proud of the veneer on both the inside of the cabinet, and the panel stiles on the outside. If you need to trim or sand after everything is put together, it's better to trim and sand these narrow edges.

Applied Paneling

With the cabinet box assembled, and the face frame in place, I marked the locations of the

applied stiles and rails on the face of the plywood (shown below, left). The front stile fits behind the edge of the face frame and is only $1\frac{1}{4}$ " wide. The stile at the back edge is 2" wide, equal to the width of the front stile added to the thickness of the face frame.

The 2"-wide middle rail is centered vertically on the side of the cabinet. The top and bottom rails are made to leave 2" exposed from the edge of the crown and base mouldings. This makes the top rail $3\frac{1}{4}$ " wide. I made the bottom rail the same width, and added a piece of $1\frac{1}{2}$ "-wide material to the bottom edge of the cabinet side for



After laying out the locations of the stiles and rails, I glued and clamped the solid-wood parts to the plywood cabinet sides. An extra piece of wood is added at the bottom edge of the cabinet to support the short leg of the base moulding.



By holding the gun upside down, and pulling the trigger with my little finger, I can nail the bead moulding from the side. The next layer of moulding will cover the holes.



Attaching a sacrificial base and fence to the miter saw lets me see precisely where the cut will be made by lining up my pencil marks with the saw kerfs.



The solid wood stiles and rails, combined with the bead, cove and crown mouldings are a simple way to produce a rich paneled look to the finished bookcase.

FORMAL-STYLE BOOKCASE

attaching the base moulding.

I used glue only to hold these in place, clamping them down and letting the glue dry for an hour. Then I began applying the trim to the inside edges. I marked the lengths of the mitered pieces directly from the corners of the stiles and rails.

Two-step Moulding

The bead moulding can be nailed from the side, because the cove moulding will cover the nail holes. I fit and placed all the bead moulding before beginning to fit the cove. I did nail the cove moulding with 23-gauge pins. These leave very tiny holes that I filled with a bit of sanding dust mixed with clear lacquer.

After all the panel moulding was on, I cut and fit the crown, and after a final sanding stained the wood with Behlen's "American Walnut" NGR stain, followed by two coats of shellac. **PW**

NO.	ITEM	DIMENSIONS (INCHES)			MATERIAL	COMMENTS
		T	W	L		
2	Sides	3/4"	9 5/8"	59 1/4"	Plywood	Mahogany
1	Bottom	3/4"	9 5/8"	27"	Plywood	Mahogany
1	Fixed shelf	3/4"	8 7/8"	27"	Plywood	Mahogany
1	Top	3/4"	10 3/8"	30"	Plywood	Mahogany
1	Back	3/4"	28"	56 1/4"	Plywood	Mahogany
2	Adj. shelves	3/4"	8 3/4"	26 7/8"	Plywood	Mahogany
2	FF stiles	3/4"	19 1/16"	59 1/4"	Solid	Mahogany
2	FF rails	3/4"	1 1/2"	27"	Solid	Mahogany
1	FF bottom rail	3/4"	4"	27"	Solid	Mahogany
2	Shelf edges	3/4"	1 1/2"	26 7/8"	Solid	Mahogany
2	Front cab stile	3/4"	1 1/4"	59 1/4"	Solid	Mahogany
2	Back cab stile	3/4"	2"	59 1/4"	Solid	Mahogany
2	Cab top rail	3/4"	3 1/4"	6 3/8"	Solid	Mahogany
2	Cab middle rail	3/4"	2"	6 3/8"	Solid	Mahogany
2	Cab bottom rail	3/4"	3 1/4"	6 3/8"	Solid	Mahogany
1	Cab bead moulding	1/2"	1 1/16"	28LF	Solid	Mahogany
1	Cab cove moulding	1/2"	1/2"	28LF	Solid	Mahogany
1	Crown moulding	3/4"	2"	60"	Solid	Mahogany
1	Base moulding	3/4"	3 3/4"	60"	Solid	Mahogany

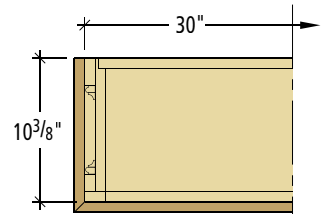

Plan

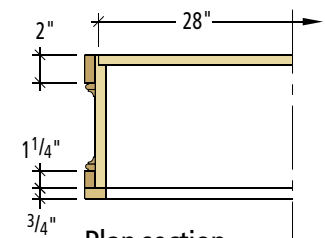

Plan section

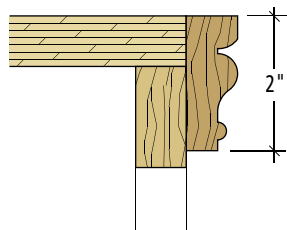

Crown moulding detail

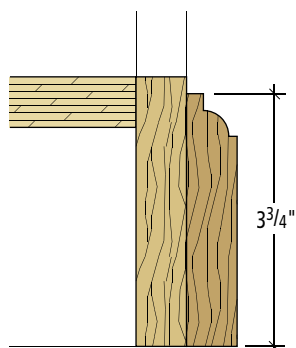

Base moulding detail

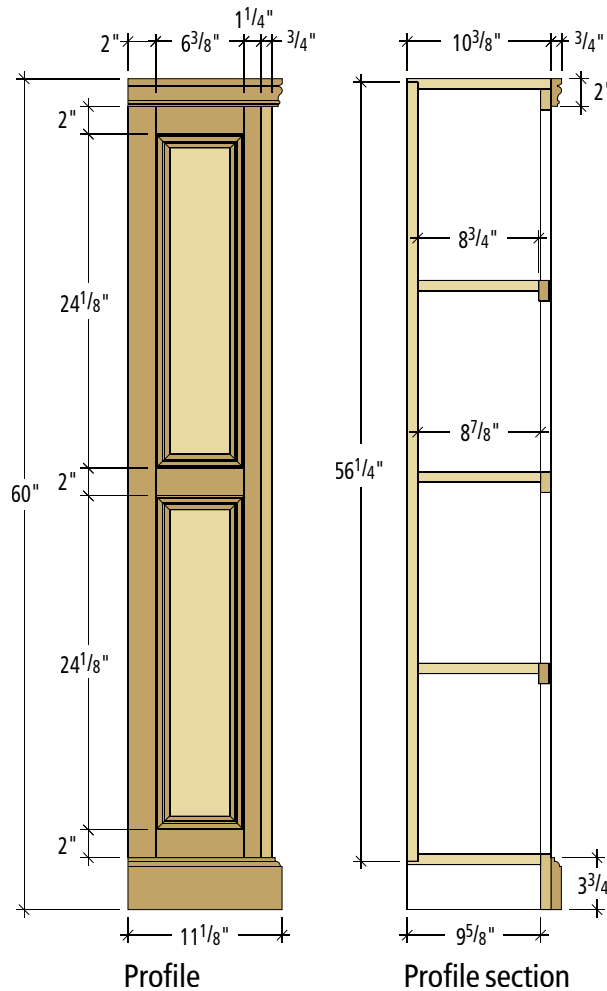

Profile

Profile section

Elevation

BUILT-IN BASICS

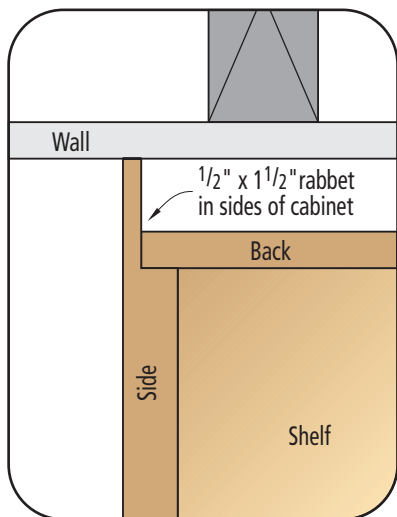

Back Rabbet Detail

Plan view

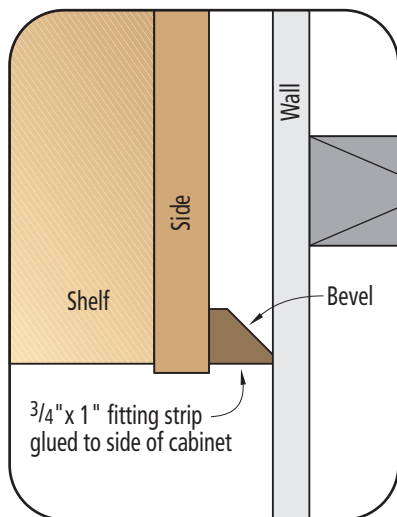

Simple fitting strip

Plan view

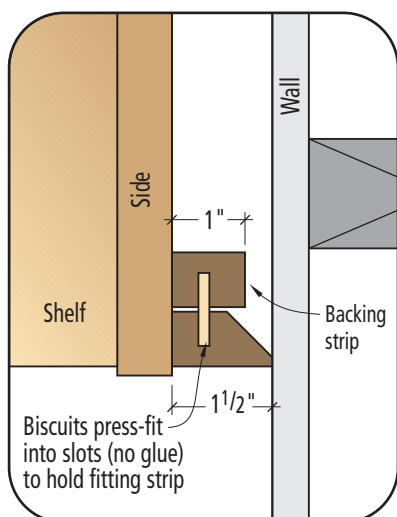

Complex fitting strip

Plan view

Making built-in furniture isn't tough. I've seen lots of first-time woodworkers build bookshelves that fit in the nooks by their fireplace.

But making built-ins that hug the wall, sit level and are anchored firmly to the house requires a little more know-how.

ably noticed that your rooms aren't all square and your walls aren't all plumb. This is usually the result of your house settling. It's also possible your framers or dry-wallers were sloppy.

Either way, don't build your cabinets crooked to fit a catawampus corner or sloping wall. Always build your projects square and add a couple features to allow them to fit in an irregular space. There are two tricks to accommodating out-of-whack walls: oversized back rabbets and fitting strips.

Making a built-in is easy once you understand scribing, fitting strips and French cleats. Here's a solid lesson in all three.

Big Back Rabbets

All cabinets should have a back that rests in rabbets in the sides of the case. This ensures a tight fit between the back and sides. With freestanding furniture, if your back is 1/2"-thick, then the rabbets for that back should be 1/2" wide. This is not so with built-ins.

You need to cut a rabbet that is significantly wider. How wide? I usually make it between 1 1/4" and 1 1/2", depending on how out of kilter the wall is.

Luckily, with a little planning and a few modifications to the plans of almost any cabinet, you can make it a built-in. After trying different systems for making built-ins, this is the one that I prefer. It's simple, rock-solid and almost foolproof.

Cabinets in a Crooked House

If you've ever hung a cabinet or built in a few shelves, you've prob-

ably noticed that this large rabbet does it creates two long tongues on the back of your cabinet that can

by Christopher Schwarz

Comments or questions? Contact Chris at 513-531-2690 ext. 1407 or chris.schwarz@fwpubs.com.

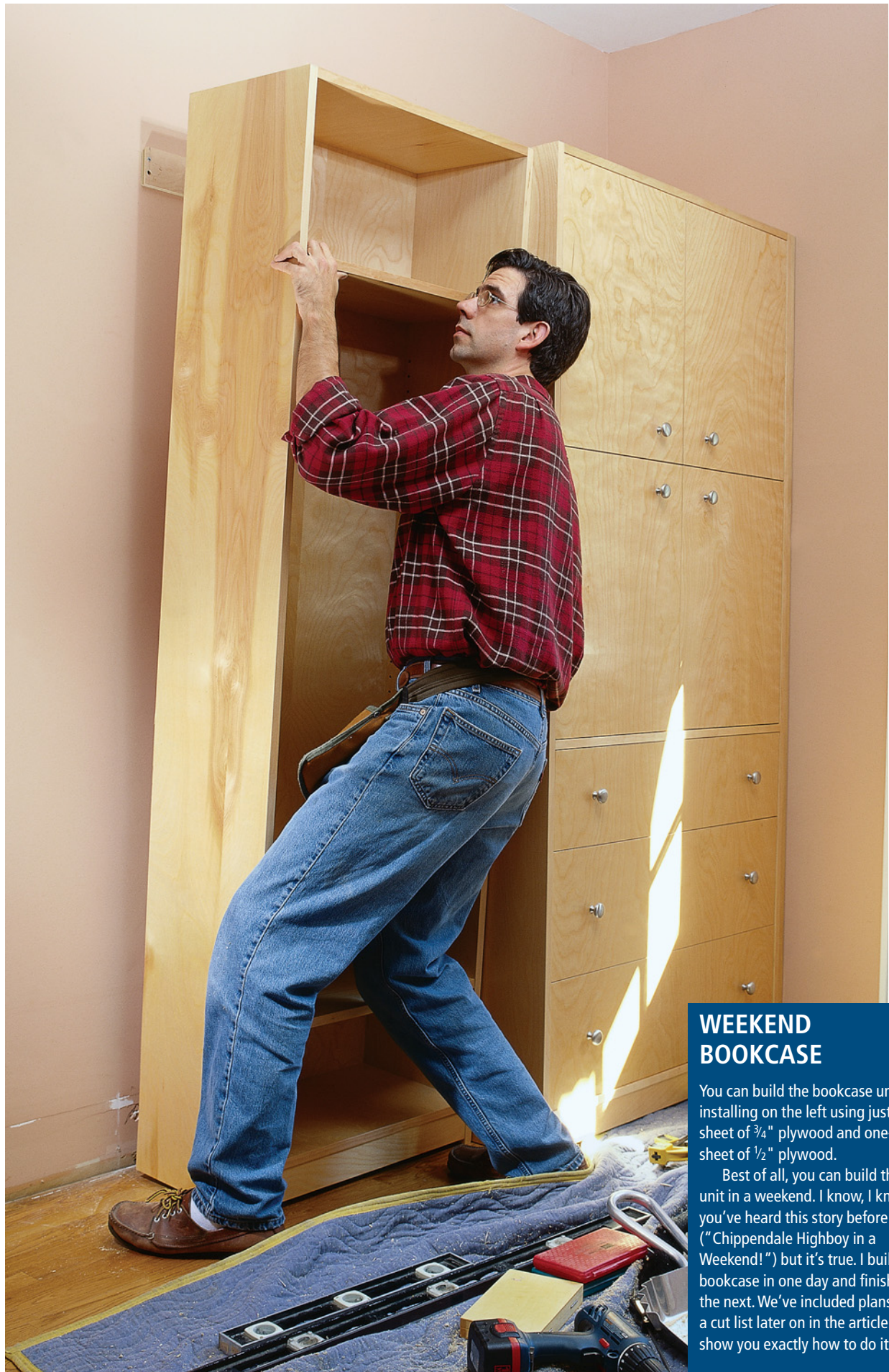

Photos by Al Parrish

WEEKEND BOOKCASE

You can build the bookcase unit I'm installing on the left using just one sheet of $\frac{3}{4}$ " plywood and one-half sheet of $\frac{1}{2}$ " plywood.

Best of all, you can build this unit in a weekend. I know, I know – you've heard this story before ("Chippendale Highboy in a Weekend!") but it's true. I built this bookcase in one day and finished it the next. We've included plans and a cut list later on in the article that show you exactly how to do it.

be scribed to fit almost any wall.

What's scribing? This is when you cut the edge of the cabinet so it matches the shape of your wall and fits tightly against it. Scribing isn't difficult, and I'll show you how I go about it later.

Fitting Strips, Scribe Stiles

"Fitting strips" and "scribe stiles" are two other weapons in your arsenal against the crooked wall. They are a lot like the large rabbets on the backside of your cabinet, except they help fit the sides of your cabinet to a wall or to another adjacent cabinet.

If you are building and installing a face frame cabinet, your best bet is incorporating a scribe stile into your design. With this technique you make your face-frame stiles (the vertical pieces of the frame) wider so they extend out over the sides of the cabinet by $\frac{3}{4}$ ". Cut a rabbet on the backside of the stiles, which makes them easier to scribe to fit, and you then have a seamless way of attaching your cabinets to walls or to other cabinets.

If you are building a cabinet without a face frame then you should turn to the fitting strip.

Fitting strips are attached to the cabinet sides and are cut to fit against a wall. Typically you cut a 45° angle on the backside of the $\frac{3}{4}$ " x 1" fitting strip so when you scribe it there is a lot less material to cut away. There are a variety of different ways to attach a fitting strip to a case. Whatever method you use, avoid using metal fasteners because they could get in the way when you scribe and then trim the fitting strip to size.

If the case is small, you can simply glue the fitting strip to the side of the case. If the case is large, you should come up with an alternate plan. It's no fun turning a big case on its side, trimming a little more and then setting it back up over and over again.

One solution is to glue a backing board to the cabinet behind the fitting strip that is a little narrower. Then you attach the fitting strip to the backing board using several biscuits but no glue. This allows you to set the cabinet against the wall, mark your scribe, cut it and then put the cabinet in place. Then you fine tune the fit by pulling the strip out for more trimming. See the drawing on the previous page.

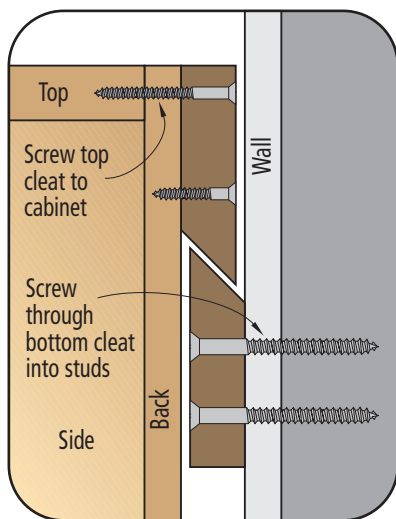

French cleat detail
Profile view



There are a wide variety of cabinet levelers you can buy, but they all basically work the same way. Many of them are adjustable at both the foot and from above through an access hole you drill in the cabinet's bottom. This feature is a huge convenience when leveling your cabinet on an uneven floor.

Attaching it to the Wall

The other big issue when installing a built-in is how you actually attach it to the wall. There are a number of ways to do it. Some people simply run some long screws through the back and into the studs. This works, but the screw heads are visible inside the cabinet, and you must use really long screws to reach into the studs across your big back rabbet.

Another solution is to install a hanging strip inside your cabinet. The hanging strip is usually a piece of $\frac{3}{4}$ "-thick material that is about 3" wide and is nailed or biscuited between the sides – right beneath the top. With this system, you attach the cabinet to the wall through the hanging strip using countersunk screws, which you can then plug to hide them.

The system I prefer uses a French cleat. It sounds complicated at first, but once you get it straight in your head you'll see it has some advantages.

The French cleat uses two cleats, each with one long edge beveled at 45°. One of the cleats is screwed to the wall and the other is screwed to the back of the cabinet. The two 45° angles nest together, locking the

cabinet to the wall. This is a common way to hang kitchen wall cabinets, but I've found it's great for hanging cabinets that go to the floor, too. And I've come up with a method that makes it easy to do. But before you can install any cabinet, the first thing you have to do is get it sitting level on the floor.

A Word About Cabinet Bases

When building large cabinets, it's best to build a separate base from the cabinet itself that is about 3" to 4" in height. You can then set the base in place and level it using wooden shims or leveler feet. Leveler feet are a piece of hardware that attaches to the inside corners of your base and have feet that screw up and down. You adjust the feet until the base is level and then set the cabinet on top of the base and move on to the section on scribing.

With smaller cabinets, such as the bookcase shown here, you can skip the separate base and install the leveler feet under the bottom shelf or use shims to level the entire cabinet. Either way, you must get the cabinet level left-to-right and front-to-back before you proceed.



Once the cabinet is level front-to-back as well as left-to-right you can plug the holes you drilled to access the leveler hardware. Many brands of levelers come with their own plastic plugs, though a shop-made tapered wooden plug works just as well.

Scribing

Scribing isn't difficult, but it requires practice. The first thing to do is take a look at your cabinet. If it is going in a corner, then you should remove the big back rabbet that goes into the corner – it's only going to get in the way of scribing the other rabbet and the fitting strip (if you have one).

Now push the cabinet back against the wall or walls until some part of the cabinet meets the wall. It's time to mark a scribe line on your back rabbet. Get a compass that allows you to lock the swinging arm. Using a ruler, find the biggest gap between your wall and cabinet. Set the distance between the pencil and the point of the compass to this distance.

Now trace the shape of the wall onto the back edge of the cabinet. Use the point of the compass to follow the wall and let the pencil draw that shape onto the cabinet. Keep the compass level.

In the photos, you'll see I use a European-style scribing tool instead of a compass. This piece of red plastic costs about \$8 (ouch), but it's a lot easier to handle than a compass. This scribing tool is sold as the McGrath Scribe and

Profile Gauge, and it is available from Diefenbacher Tools, 800-326-5316 or diefenbacher.com. Ask for item # 663-1000.

Once you've drawn your scribe line, trim the back rabbet to that line. You can use a jigsaw followed by a hand plane, a belt sander or even a hand-held power planer. Test the fit of your scribe line to the wall and make any necessary corrections.

Once the back is fit, scribe the fitting strip (if you have one) where the front of the cabinet meets the wall. Once everything fits snugly, attach the case to the wall using your French cleats.

Installing French Cleats

It's simple to get a perfect fit with these cleats if you follow these steps. I like to use plywood or any tough hardwood such as maple for the cleats. First rip your two cleats to about 3" wide and cut them to length so they're about 1" shorter than the width of the back of your cabinet. If your back piece is 23½" wide, then cut the cleats to 22½" long – this gives you some left-to-right play during installation.

The first step is to install a

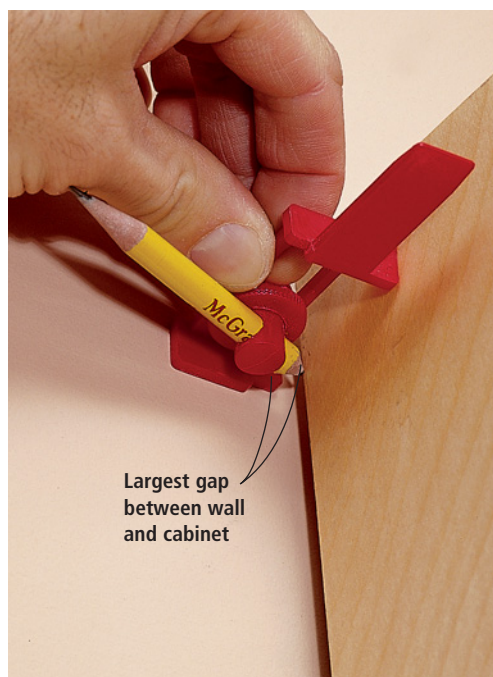

To set your scribing tool, use a ruler to find the biggest gap between the back edge of your cabinet side and the wall. Set your scribe to span this distance exactly. Now run the scribing tool up the back edge of your cabinet – being sure to maintain contact with both the wall and cabinet. The pencil will draw your cut line on the back edge of the cabinet side.

Largest gap between wall and cabinet



Scribe line

Many professionals use a belt sander to remove the material down to the scribe line. Belt sanders are a little too speedy for my tastes. I prefer to use a jigsaw to cut right up to the line and then clean up the cut with a block plane. It's still quick, and there's little chance of obliterating your scribe line.



Install the first French cleat to your wall using the longest screws available. These screws must anchor the cleat into the stud wall of your house, or the cabinet could come toppling down if someone tries to climb it.

cleat on the wall so it's perfectly level and about 2½" below where the top of the cabinet will touch the wall. Screw the cleat to at least two studs in your wall using #10 x 3" screws.

Now push the cabinet in place against the wall and use a stepladder so you can work on the top of the cabinet. Take the other cleat and drop it behind the cabinet and push it into place with the bevel facing the back of the cabinet. It should drop into place with ½" or so sticking above the top of the cabinet. Mark a line on the cleat where the back and cleat intersect. Lift the cleat out and rip the cleat to width exactly to your line.

Pull the cabinet away from the wall and screw the cleat to the backside of the cabinet so the top edge of the cleat is perfectly flush to the top of the cabinet.

With the help of an assistant, lift the cabinet a few inches and place it on the cleat on the wall. The cabinet should sit flush against the wall, flat on the floor and refuse to rock or move.

If the cabinet doesn't sit on the floor, remove one cleat and shave off a tad from the bevel with a hand plane or a jointer. Or you can adjust the leveling feet. If the

cabinet rocks a bit on the cleat, add a short strip or two of masking tape to the bevel on one cleat and that will tighten things up.

There's another type of cleat that some prefer. Instead of ripping a 45° bevel on each long edge, cut a rabbet on each long edge. The rabbet should be exactly one-half the thickness of the cleat so that the cleats nest together like a shiplap joint.

Install the first cleat against the wall. When you attach the second cleat to the cabinet, nudge it up ⅛" and then screw it in place. This will prevent the rabbets from bottoming out when they nest and will give you a little play when the cabinet rests on the floor.

Cleaning Up

With the cabinet in place, you might have to screw one of the side pieces to a wall to pull the cabinet tight against the wall.

The cabinet is now complete, except for any trim around the base and crown. To finish the run of cabinets shown at the beginning of the article I still need to build and install another large unit with drawers and doors. Then comes the trim moulding. And then comes a cold beer. **PW**

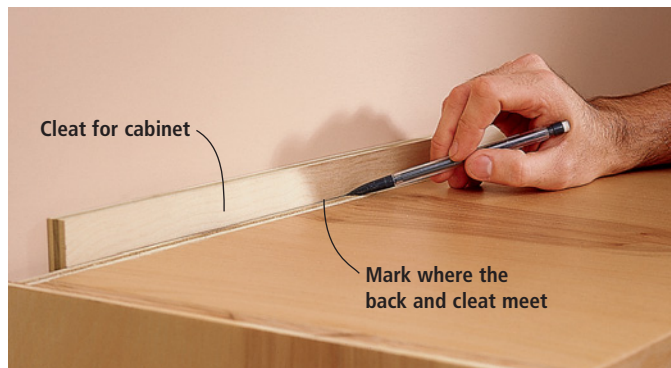

With the back rabbet scribed and a cleat screwed to the wall, push your cabinet in position and drop the second cleat in place behind the cabinet back. Using a sharp pencil (top), mark a line on the cleat where the cabinet back and cleat meet. Remove the cleat (bottom) and rip it to width. If you had to scribe near the top of your cabinet, you might have to plane down your cleats a tad, too.



Clamp your cleat to the back of the cabinet with the top edges of the cleat and cabinet back perfectly flush. If they're out of kilter you're going to make trouble for yourself, so take care. Screw the cleat to the cabinet using long screws that you countersink into the cleat.

THE ONE-WEEKEND BOOKCASE

When I build a project for my family, I'll come up from the shop and the first words out of their mouths are usually something like: "Aren't you done making my (corner cabinet, entertainment center, Morris chair, carved weasel) yet?"

Well this time the joke was really on them. I went down to the shop at 8 a.m. one morning and by 5 p.m., this bookcase was sanded, assembled and ready for finishing. They were shocked.

There's nothing fancy about this basic bookcase unit, but it does hold a ton of stuff, is inexpensive to build (about \$70 in materials) and goes together as fast as a highboy on "The New Yankee Workshop." Well, OK, it's not quite that fast.

Follow the photos and drawings to build your own. But be forewarned. Once you build something this fast, your family is going to think you spend most of your time in the shop just goofing off.

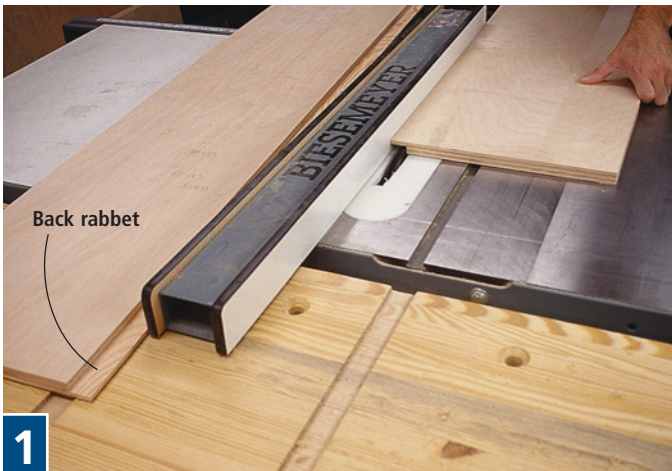

1

Begin by cutting the big $1\frac{1}{4}$ " x $\frac{1}{2}$ " back rabbet on the back edge of the sides. The most accurate way to make this rabbet is by using a dado stack in your table saw. Make a couple passes and be sure to keep even downward pressure.

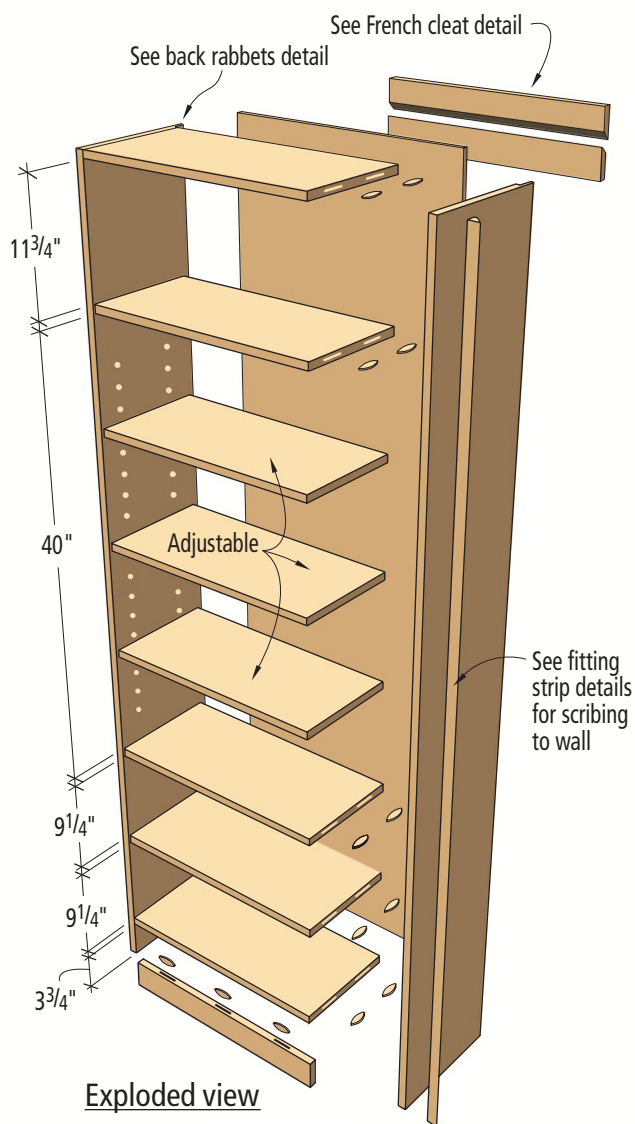

THE ONE-WEEKEND BOOKCASE

NO.	ITEM	DIMENSIONS (INCHES)			MATERIAL	COMMENTS
		T	W	L		
□ 2	Sides	$\frac{3}{4}$	12	80	Plywood	$\frac{1}{2}$ " x $1\frac{1}{4}$ " rabbet for back
□ 2	Top and bottom	$\frac{3}{4}$	$10\frac{3}{4}$	$22\frac{1}{2}$	Plywood	Biscuited into sides
□ 3	Fixed shelves	$\frac{3}{4}$	$10\frac{1}{2}$	$22\frac{1}{2}$	Plywood	Biscuited into sides
□ 3	Adjustable shelves	$\frac{3}{4}$	$10\frac{1}{2}$	$22\frac{3}{8}$	Plywood	
□ 1	Kick	$\frac{3}{4}$	$3\frac{3}{4}$	$22\frac{1}{2}$	Plywood	Biscuited into bottom
□ 1	Back	$\frac{1}{2}$	$23\frac{1}{2}$	78	Plywood	
□ 1	Fitting strip	$\frac{3}{4}$	1	80	Plywood	Use if unit goes in corner
□ 2	French cleats	$\frac{3}{4}$	3	$22\frac{1}{2}$	Plywood	45° bevel on one long edge

You can download an optimization chart for this project at: popwood.com/features/mag.html



2

To lay out the location of your shelves, clamp the two sides together and use a framing square to mark the shelf locations. Use the drawing to lay out the locations of the fixed shelves, top and bottom pieces.

If you work in a small shop (like I do) the No. 1 challenge with a piece of furniture like this is cutting down the plywood into manageable sizes for my table saw.

Luckily, Nick Engler showed me how to do it quickly and accurately. Engler made a simple platform from 2 x 4s that you place on two sawhorses in your driveway. Using a special shop-made fence and a circular saw you can make perfect cuts in sheet goods.

The original article appeared in the April 2001 issue. If you don't have that back issue, we've posted this article on our web site at popularwoodworking.com. When you get to our home page, click on "Select Articles," scroll down and you'll see the article titled "Sawing Plywood and Particleboard."

I've built many cabinets using this simple jig and highly recommend it.

Screws or Biscuits?

I built this project using biscuits and a 1/2"-thick back, which makes the case quite rigid. Another possible approach is to screw the fixed shelves in place through the side pieces using #8 x 2" screws.

If the sides of your bookcase aren't going to show (or you don't mind the look of plugs) this is a solid way to make a bookcase.

One final option I'm fond of with large cabinets is to use both biscuits and pocket screws together. This hybrid system is about the fastest and most accurate way I know to build a case.

First cut the biscuit slots, then cut the pocket holes on the underside of the shelves. Glue up the case and then drive the screws home. The biscuits line up all your joints perfectly, and the screws allow you to do this all without any clamps at all. **PW**

SUPPLIES

Lee Valley Tools
800-871-8158
leevalley.com

Cabinet Levelers, One-ton Glide
Each glide is rated for 2,000 pounds. Foot adjusts over a range of 2 1/4".
Item # 01508.01, \$3.70 each

Nickel-plated Shelf Supports
Item # 94Z04.02, \$3.50 for a package of 50.



3

Template helps lay out biscuit locations

All the permanent shelves are attached to the sides using biscuit joints. Clamp the shelves at the location where they will join the sides. I then made a simple template to lay out the locations of my biscuit slots. This saves a lot of measuring.



4

Take the fence off your biscuit joiner (or retract the tool's fence fully into the fence assembly). Cut three biscuit slots in the shelves as shown. I used #10 biscuits because I was out of #20s.



5

Now turn the biscuit joiner on its head and cut the slots in the sides pieces of the cabinet.



6

Iron on some adhesive edge-banding to cover all the visible plywood edges. Use a household iron set on "high." After a couple minutes of ironing, take the iron off the tape and use a sizable block of wood to rub the edging down. The wood acts as a heat sink to cool the adhesive and set the edge-banding in place.

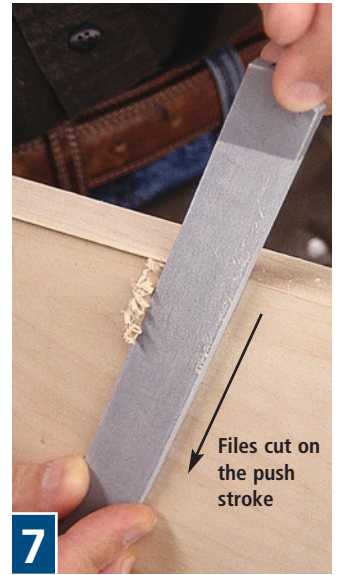

7

Use a file to trim the overhang of the edge-banding. Remember that files cut only in one direction. Move them the other way and they'll cut poorly and dull quickly. Now sand all your parts at 150 grit and then 220 grit.

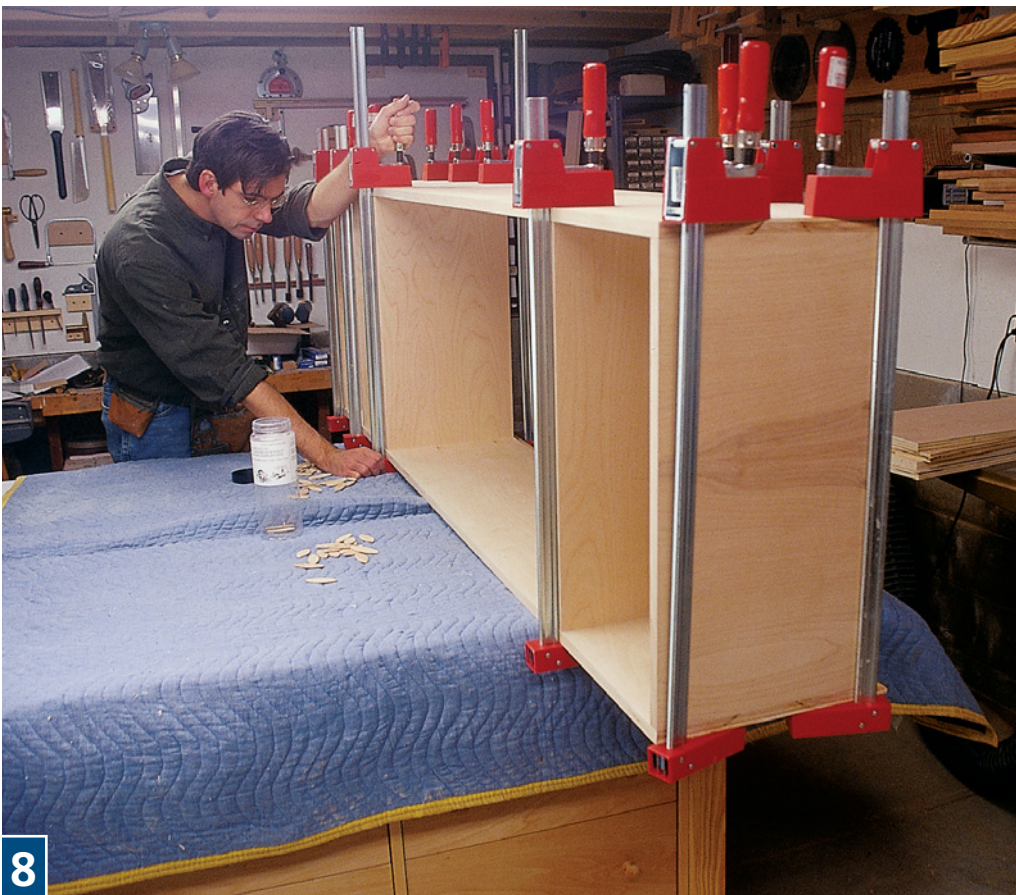

8

Always do a dry run before gluing up your case. Once you're sure everything works, use a slow-setting glue. I have become quite fond of the new Titebond Extend glues. They are very strong and give you just enough working time to get a big case together by yourself. Once the glue is dry, cut the back to size. You want a perfect fit because the back will keep the cabinet square once it's screwed in place.



9

Drill your shelf pin holes every 2" on center. You can use a commercial jig like the one shown or make your own from scrap. Then attach the kick to the bottom using glue plus biscuits or pocket screws. I finished the bookcase with two coats of spray lacquer in the backyard on a nice breezy day.

BIBLIOPHILE'S BOOKCASE

BY MEGAN FITZPATRICK

With simple lines and straightforward joinery,
this project yields ample shelf space (and drawers to boot).

This large case-on-case shelving unit is adapted from similar pieces I've seen in private libraries and in stately homes. I also dug up a few pictures from the Sotheby's and Christie's auction sites, where the form is referred to as a "bibliotheque" (also the French word for library).

Those examples, however, all feature intricate mouldings and fancy corbels and are more adorned than would look right in my less-than-stately 1895 home. I do, however, have 10' ceilings and an embarrassment of books, so while I didn't want fancy, I did want big. So I reconceived the form in a Shaker-on-steroids style – the piece is just shy of 50" wide x 90" high. It will fit in a room with standard ceiling heights, but in case I ever needed to use the top and bottom separately, I installed a solid top for the bottom case so it can stand alone (and with the addition of a cushion, it would make a handsome hall bench).

The size did have me fretting about stock costs, so I culled the "shorts" bin at our local lumber store for lower-priced cherry, and found a nicely figured wide piece for the drawer fronts, as well as sufficient stock for the lower case and all the shelves. The shelves are made of some rather homely boards,

but because I added a lip to the front for strength and appearance, you can't actually tell – unless you remove the books and take a close look. I did have to go to the regular-price rack for the upper-case face frame and sides, but I saved money by using poplar for the backboards, which I painted to match the trim in the living room.

Bottom's Up First

First, I cut my parts to rough sizes then surfaced and thickened all the stock but the drawer fronts, and glued up panels for the sides, lower case top and upper case top, and all the shelves. I never cut my pieces to final size until I need them – and then I mark cuts using the project as a guide, not the cutlist. No matter how meticulous I am with the measuring, things are never perfect. But, once my pieces are cut to size, I plane and finish-sand as much as possible before assembly because it's hard to maneuver around a piece the size of a New York apartment.

Because I didn't have a 7"-wide piece for the lower rail, or two 49"-long pieces with matching grain that I could glue up, I had to scab on a 4" x 14" piece at each rail end for the curved feet (the downside of parsimony).

I then traced my pattern onto each foot,

cut it at the band saw and smoothed the cuts on a spindle sander – but had to resort to hand-sanding where the curve met the **f** at.

After setting up the mortiser with a 1/4" bit, I made a 1 1/2"-wide mortise for the 2"-wide center stile dead in the middle of the lower rail, then moved to the table saw to cut 1 1/4"-long tenons on each end using a dado stack.

Holding the workpiece took a little thought, because the two feet created a not-solid surface on the bottom edge (a good argument for spending a little extra to make the lower rail and feet out of one board – or at least a solid panel glue-up, and cutting the tenons before cutting out the feet). But no worries – a 3"-long offcut clamped to the sliding table did the trick. I cut each tenon face in two passes, first removing 3/4" or so at the end before pushing the end against the fence to remove the remainder of the waste on each shoulder.

The resulting tenon was 6 1/2" wide – on the cusp of too wide to offer sufficient mortise-wall strength – so I split it by sawing out a 1"-wide piece with a coping saw, then chiseled the shoulder flat while removing the remaining waste. I cut 1 1/4" tenons on the upper rail and center stile at the table saw,



Simple shelves. Though it's large, this Shaker-inspired bookcase is fairly simple to make – and three adjustable shelves make it simple to fit books of all sizes.



Scabby feet. Because I had very little extra stock, and not enough with matching grain to glue up a solid panel for the curved bottom rail, I had to scab on the foot piece at either end.



Cut the curve. I traced my pattern onto each foot and made the cuts at the band saw.

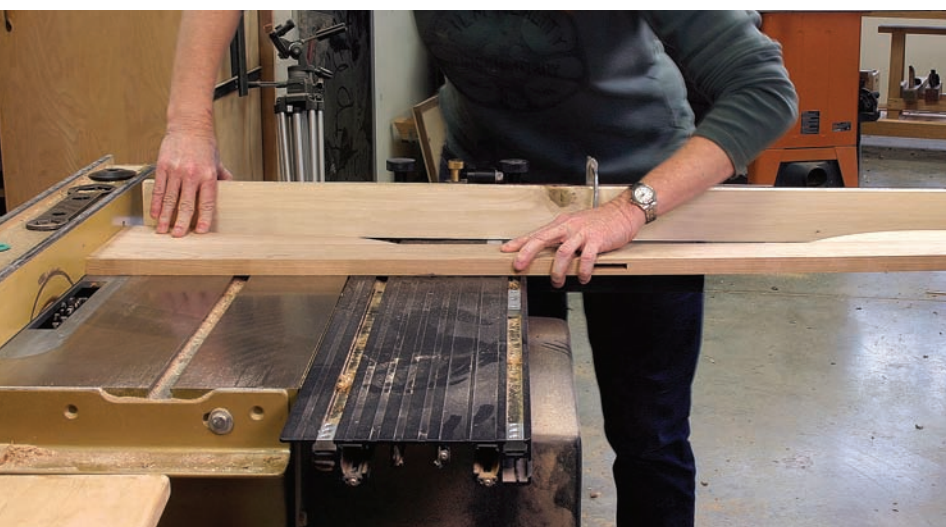

Jigged up. Because the feet created a non-flat surface, and the sliding table is shorter than my workpiece, I simply clamped a flat piece of scrap to the fence against which I could hold the rail while I made the tenons.

marked then cut the mortises on the side rails at the mortiser. After I glued together the face frame and set it aside to dry, it was on to the side pieces.

I marked the curved cutout on each piece, then made the cuts at the band saw. (Note: the apex is not centered; it's $\frac{3}{4}$ " closer to the front.) Because the full dado stack was still in place, I went ahead and added a sacrificial fence, then cut a $\frac{3}{4}$ " x $\frac{7}{16}$ " rabbet up the back of each side piece to house the backboards. In retrospect, I should have cut an 11" stopped rabbet, because the backboards don't go all the way to the floor. While the unnecessary 7" portion of rabbet doesn't show, the base would be stronger without it.

I adjusted the dado stack to make a $\frac{3}{4}$ "-wide cut, and made a $\frac{1}{4}$ "-deep dado across each side piece 7" from the bottom (the top edge of the dado is flush with the top of the lower front rail) to accept the web frame, which is joined with pocket screws. I glued the web frame into the dados on each side, squared it up and tightened the clamps. After the glue dried, I glued on the face frame and attached a rail across the top of the back, flush with the backboard rabbets, with pocket screws.

Upper Case

First, I cut the mortises and tenons for the face frame and glued it together (luckily, no one had adjusted the mortiser from when I did the lower face frame). I made it about $\frac{1}{8}$ " oversized on the sides (as I did with the lower case face frame), so I could flush it easily to the sides later with a flush-trim router bit.

Then it was on to the side pieces, and cutting dados for the bottom and middle fixed shelves. Workholding was tricky here, because the side pieces are $70\frac{1}{2}$ " long—well over the edge of the saw table. So, I clamped a handscrew around the crosscut sled fence, on which to rest the overhanging part. This, however, meant I couldn't use the stop on the sled, so a stepoff block on the fence solved the problem to locate the $\frac{3}{4}$ " dados for the fixed bottom shelf.

I also cut $\frac{3}{4}$ " dados in each side $30\frac{3}{8}$ " from the bottom for the center fixed shelf, and marked and drilled holes for the adjustable shelf pins. The locations were figured from a graduated shelf progression—but with the remaining three shelves adjustable, it's unlikely that progression will ever be evident.



Split tenon. A 6½"-wide tenon is too big, so I split it using a coping saw then chiseled out the remainder of the waste.

Stiff Lips

With the sides done, I cut the bottom and middle shelves to size (note that the widths are different; the bottom shelf has no lip), and glued a 1½"-wide lip across the front edge of the middle shelf, leaving just better than ¼" of the shelf's front edge uncovered at each end to slip into the dados.

After the glue dried and I sanded the lip flush, I ran a bead of glue in each side-panel dado, set the fixed shelves in place flush with the front edge of the side, clamped across, then toenailed the fixed shelves in place. Be careful with the angle of your nail gun and the length of your nails. I blew through the side once. OK, maybe three times.

While that glue-up dried, I added lips to the three adjustable shelves, keeping them just shy of either end to make shelf adjustment easier (the face frame covers the shelf ends, so the gap won't show).

Next, I added the face frame, and got a little help clamping it up square – there was simply no way for me to reach corner to corner to pull things into place without assistance. Then, I pocket-screwed a rail at the top edge to which I later attached the backboards.

Topping Things Off

I cut the upper- and lower-case tops to size, and rounded over the edges with #80-grit sandpaper until I liked the way it looked, then progressed through grits to #180 until the shaped edge was smooth.

The lower-case top is attached with L-shaped wood buttons, and has a 1" overhang on the front and at each side; the upper-case top (to which the crown attaches) has a 2⅞" overhang on the front and either side. It's screwed to the back rail, sides and face frame.



Framed. The pocket-screwed web frame was glued into the side panel grooves and squared up before I tightened down the clamps.



More jigs. Again faced with secure workholding problems at the table saw, I used a handscrew attached to the sliding table to support one end, and an stepoff block at the other to safely locate the groove for the bottom fixed shelf.



Toenails. Be sure you have ¼" nails in your gun – or if it's loaded with ½" nails, make sure you angle your shots enough so that you don't blow through the sides. Or keep the nippers handy.



A little help please. With a big glue-up, it's best to rope a friend into helping. By oneself, it's difficult to tighten all the clamps down quickly without things sliding around – or reach corner to corner should you need to square things up. Or click a camera button from 9' away.



Crown moulding. To make a simple crown, angle your stock at 45° to the blade and center the blade on the stock (or cut it just off-center so you have a thicker flat on one edge, if you like that look). Then clamp a long offcut beyond the blade to serve as a fence. Make repeated cuts in each piece of stock, raising the blade a little each time. Stay tight against your fence and to the table. Though I'm not wearing one here, a dust mask would be a good idea.

Bibliophile's Bookcase

NO.	ITEM	DIMENSIONS (INCHES)			MATERIAL	COMMENTS
		T	W	L		
Upper Case						
☐ 1	Upper rail	3/4	5 3/4	47 3/16	Cherry	TBE*
☐ 1	Lower rail	3/4	3	47 3/16	Cherry	TBE
☐ 2	Stiles	3/4	2 5/8	70 1/2	Cherry	
☐ 2	Sides	3/4	11 1/4	70 1/2	Cherry	
☐ 1	Bottom fixed shelf	3/4	10 1/2	48 15/16	Cherry	
☐ 1	Middle fixed shelf	3/4	9 3/4	48 15/16	Cherry	
☐ 3	Adjustable shelves	3/4	9 3/4	48 1/4	Cherry	
☐ 4	Shelf lips	3/4	1 3/4	48	Cherry	
☐ 1	Top	3/4	14 7/8	55 11/16	Cherry	
☐ 2	Crown	3/4	4 1/4	54	Cherry	Rough size
☐ varies	Backboards	5/8	varies	70 1/2	Poplar	
Lower Case						
☐ 1	Upper rail	3/4	3	47 3/16	Cherry	TBE*
☐ 1	Lower rail	3/4	3	47 3/16	Cherry	TBE
☐ 2	Feet	3/4	4	14 1/4	Cherry	TOE**
☐ 2	Outer stiles	3/4	2 5/8	18	Cherry	
☐ 1	Center stile	3/4	2	10 1/2	Cherry	TBE
☐ 2	Sides	3/4	12 3/4	18	Cherry	
☐ 1	Top	3/4	14 1/2	51 15/16	Cherry	
☐ 2	Drawer fronts	3/4	8	21 1/4	Cherry	Size sides, bottom to fit
☐ varies	Backboards	5/8	varies	11 3/4	Poplar	
Web Frame						
☐ 2	Long rails	3/4	2 1/2	43 15/16	Poplar	
☐ 2	Short rails	3/4	2 1/2	12	Poplar	
☐ 1	Center stile	3/4	4	7	Poplar	

* Tenon both ends, 1 1/4"; ** Tenon one end

A Dusty Crown

I dislike making crown moulding. It is incredibly dusty, and my arms get an unwanted (but not unneeded) workout pushing 3/4" stock at an angle across the table saw blade. But there's no getting around it. So I had to set up the table saw, suck it up (the dust, that is) and get it done. And then there's the sanding. Lots of sanding.

The simplest way to fit the crown is to invert the upper case, then wrap the moulding around the front and two ends. Secure it to the top, sides and face frame with brads.

Put Your Back Into It

My backboards are shiplapped random-width poplar, and in the upper case they're painted. I did cut a chamfer on the front of each for added visual interest – not that it will show when the case is loaded with books.

In the lower section, the backboards are unpainted and have no chamfer – but they do run vertically to match the top. (If you

Online EXTRAS

To watch a video of making crown moulding and for more information on fitting crown, go to:

popularwoodworking.com/dec09

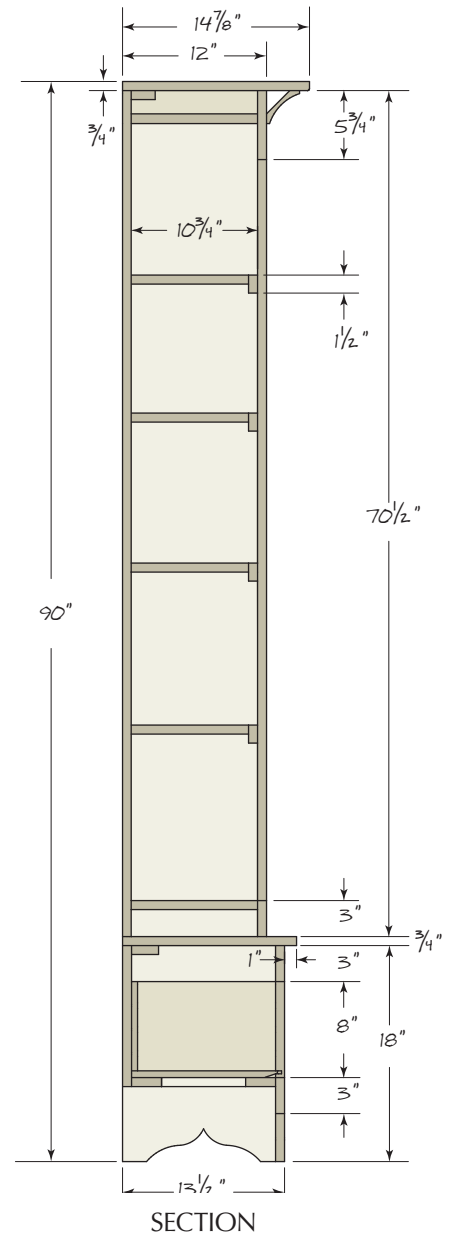
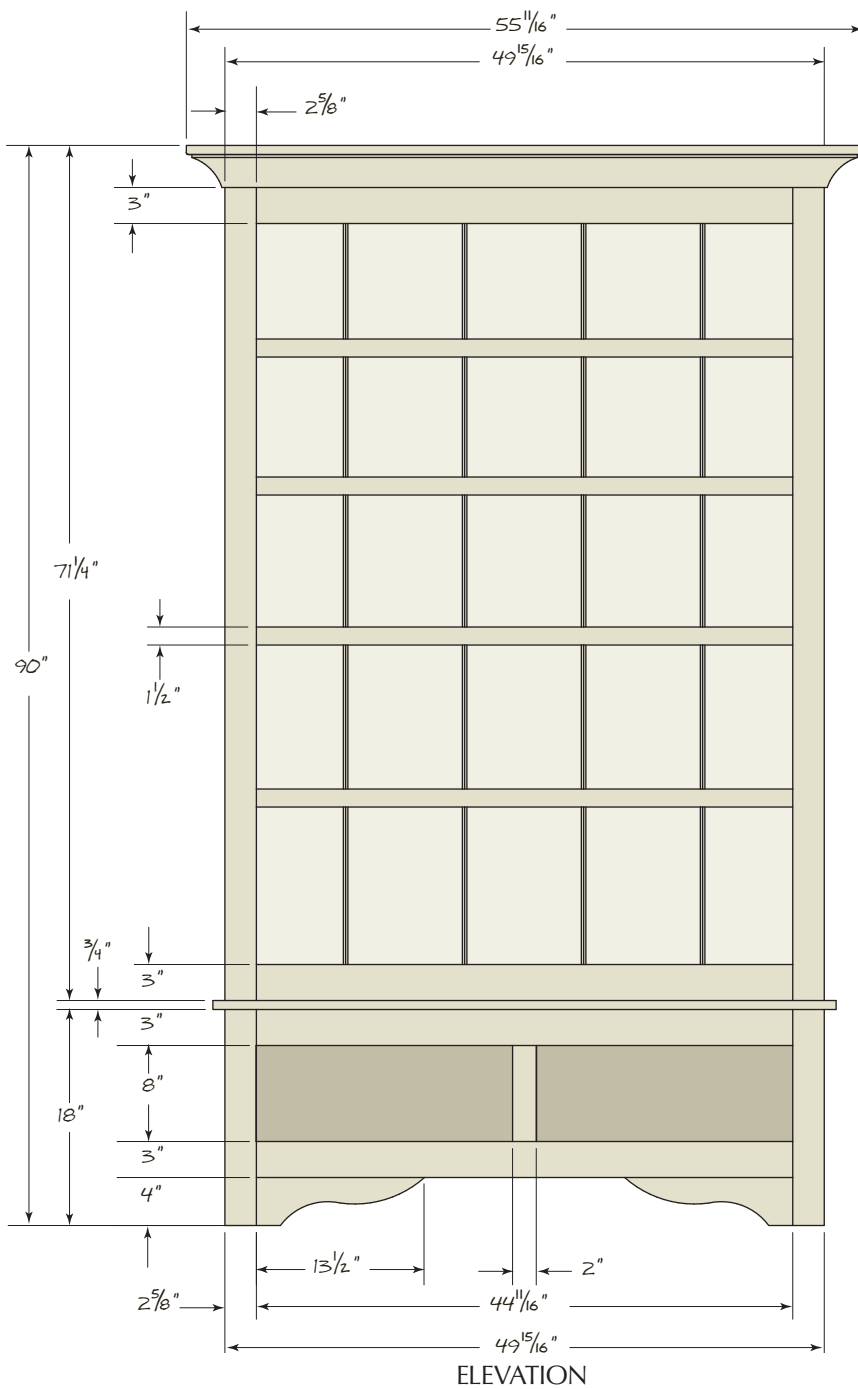

have an 11"-wide piece, you could get away with one board, run horizontally. But your co-workers might snicker at the idea.)

Hidden Storage

Last, I fit the inset drawer fronts and constructed drawers with half-blind dovetails at the front, and through-dovetails at the back. The bottom is an upside-down raised panel slid into a groove (the back edge isn't beveled), then secured to the drawer back with a 1 1/2"

shingle nail. I suspect these drawers would have originally housed candles and perhaps paper and writing implements; I'm using them to store extraneous cat toys.

The finish is two sprayed coats of amber shellac (with sanding after each) and a top coat of pre-catalyzed lacquer. **PW**

Megan is managing editor of this magazine. She can be reached at 513-531-2690 x11348 or megan.fitzpatrick@iwmedia.com.

Supplies

Rejuvenation

888-401-1900 or rejuvenation.com

4 ■ square bin pulls in oil-rubbed bronze #EC 7004, \$7 ea.

Rockler

800-279-4441 or rockler.com

1 ■ 16-pack of 1/4" shelf supports #33902, \$4.89

Prices correct at time of publication.

Get More Great Woodworking Resources!

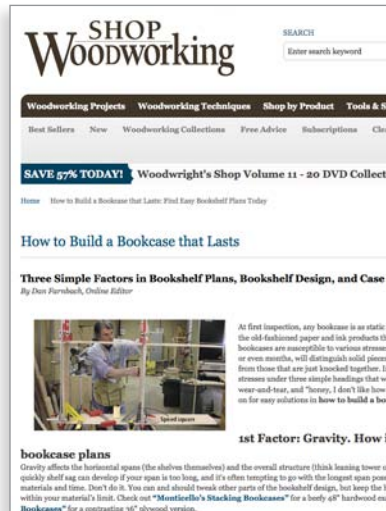
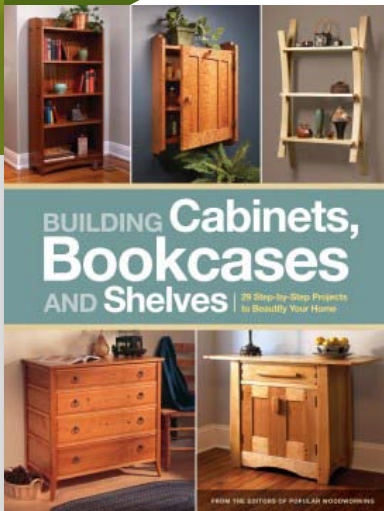

Your free download is an excerpt from the June 2005, February 2003 and December 2009 issues of *Popular Woodworking Magazine* and is just a sample of the great projects you can find in the ShopWoodworking.com store. Buy more projects today, and continue building your knowledge!

**Buy the full contents today,
and continue building
your knowledge!**